

# Z874-12 Perma-Trench HDPE 12" Drain System

Supplied By:

**TRENCHDRAIN SUPPLY**  
877-903-7246  
www.trenchdrainsupply.com

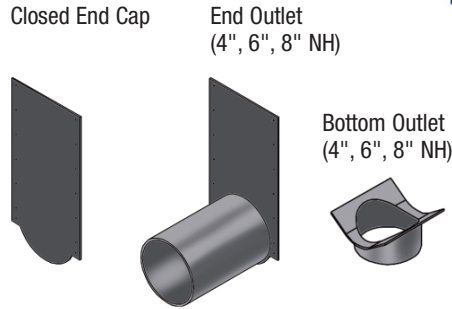
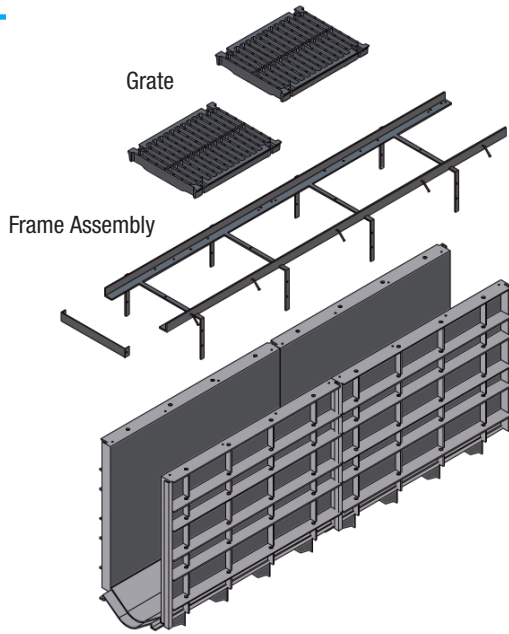

### Z874-12 Dimensional Data

Trench Number	Shallow Invert		Deep Invert		Max. Flow Rate		
	Inches	mm	Inches	mm	CFS	GPM	LPS
1201P	9.250	184	10.082	205	3.306	1475	93
1202P	10.082	205	10.914	226	3.941	1758	111
1203P	10.914	226	11.746	248	4.589	2048	129
1204P	11.746	248	12.578	269	5.248	2341	148
1205P	12.578	269	13.410	290	5.915	2639	166
1205NP	13.410	290	13.410	290	-	-	-
1206P	13.410	290	14.242	311	6.589	2939	185
1207P	14.242	311	15.074	332	7.268	3243	205
1208P	15.074	332	15.906	353	7.953	3548	224
1209P	15.906	353	16.738	374	8.641	3855	243
1210P	16.738	374	17.570	395	9.333	4164	263
1211P	17.570	395	18.402	417	10.028	4474	282
1212P	18.402	417	19.234	438	10.726	4785	302
1213P	19.234	438	20.066	459	11.426	5098	322
1214P	20.066	459	20.898	480	12.128	5411	341
1215P	20.898	480	21.730	501	12.832	5725	361
1215NP	21.730	501	21.730	501	-	-	-
1216P	21.730	501	22.562	522	13.538	6040	381
1217P	22.562	522	23.394	543	14.244	6355	401
1218P	23.394	543	24.226	565	14.953	6671	421
1219P	24.226	565	25.058	586	15.662	6988	441
1220P	25.058	586	25.890	607	16.372	7304	461
1221P	25.890	607	26.722	628	17.084	7622	481
1222P	26.722	628	27.554	649	17.796	7940	501
1223P	27.554	649	28.386	670	18.509	8258	521
1224P	28.386	670	29.218	691	19.223	8576	541
1225P	29.218	691	30.050	712	19.937	8895	561
1225NP	30.050	712	30.050	712	-	-	-
1226P	30.050	712	30.882	734	20.652	9214	581
1227P	30.882	734	31.714	755	21.367	9533	601
1228P	31.714	755	32.546	776	22.083	9852	622
1229P	32.546	776	33.378	797	22.800	10172	642
1230P	33.378	797	34.210	818	23.517	10492	662

### Z874-12 Applications

- Highways
- Airports
- Parking Lots
- Car Washes
- Industrial Parks
- Airplane Hangars
- Port Facilities
- Pharmaceuticals
- Industrial Plants
- Chemical Plants

### Installation Specification

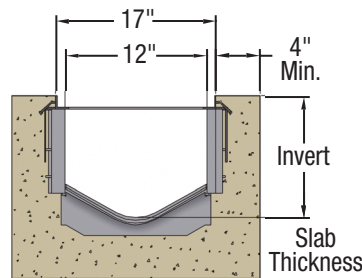

12" Throat / 17" Overall Width

**Engineering Specification** Channels shall be 80" long, 17" wide, and have a 12" wide throat. Modular channel sections shall be made of High Density Polyethylene (HDPE), have interlocking ends, and radiused bottom. Channel shall be provided with no slope (neutral) or with a 1.00% built-in slope. Channels shall be available with inverts ranging from 9.25" to 34.21". Channels shall have clips attached to the frame to accommodate vertical rebar for positioning and anchoring purposes. Choice of class A, B, C, E, and F grates shall be available with H-20 and/or FAA load ratings and/or ADA compliance with mechanical lockdown devices. A heavy-duty steel frame shall be provided to distribute weight between the grates and the HDPE channel. End caps and catch basins shall be available to complement the channels and grates. End outlets, bottom outlets, and side outlets shall be available in 4", 6", and 8" diameters. Trench drain shall be Flo-Thru model Z874-12.